



HEMAN 175

SKID STEER LOADER

ONE MAN ARMY



VERT EQUIPMENT
PRIVATE LIMITED



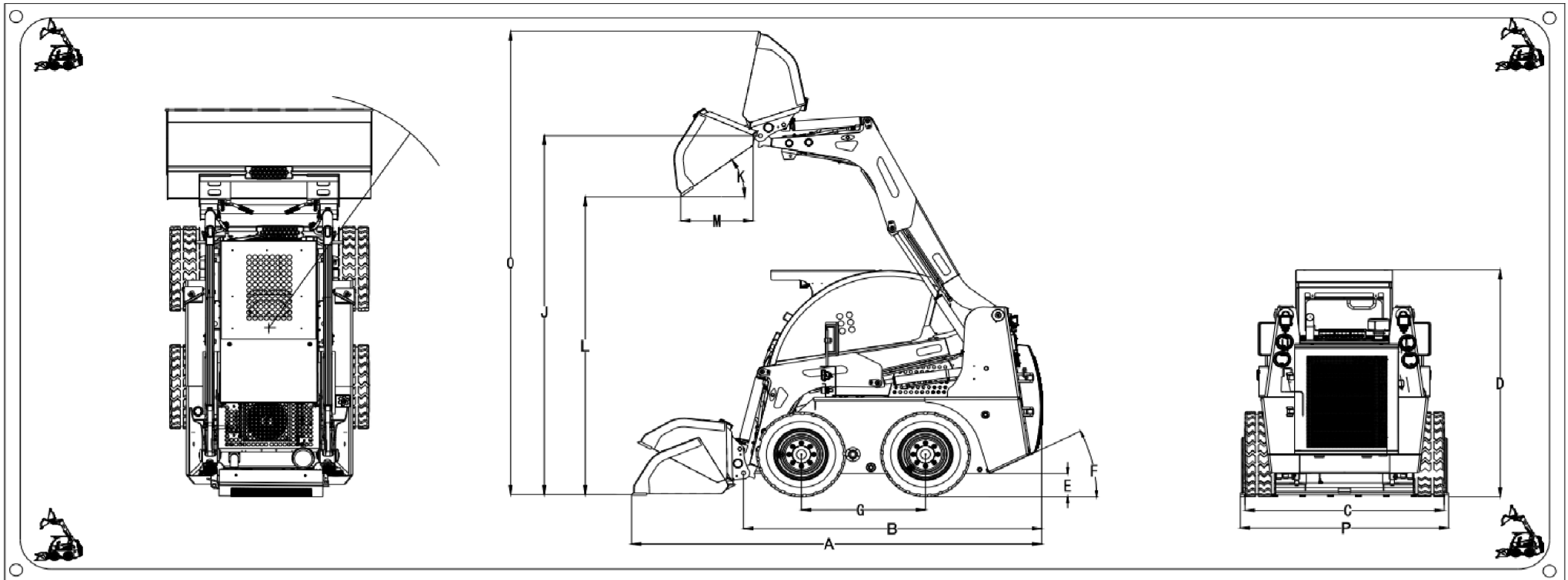

SKID STEER LOADER

		mm/deg	
DIMENSIONS	A	Length with bucket	3512
	B	length without bucket	2470
	C	Width with tyres	1622
	D	Overall height	1960
	E	Ground clearance	218
	F	Departure angle rear	26
	G	Wheelbase	1023
	H	Turning radius rear corner	2000
	I	Turning radius bucket corner	2680
	J	Pin height	3022
	K	Dump angle	40
	L	Dump height	2210
	M	Reach at dump height	715
	N	Roll back angle at ground	28
	O	Max reach at full height	4081
	P	Bucket width (standard)	1710
SAE operating weight		2690 kgs	
SPECIFICATION	Standard bucket capacity	0.40/0.46cum	
	Maximum lift height	2955mm	
	Time to raise lift arms fully	3-5 sec.	
	Breakout force -bucket	18850N	
	Breakout force -lift arm	14450N	
	Load at maximum reach	800 (kg)	
	Type of fuel	Diesel low Sulphur	
	Number of forward speed	one	
	Number of reverse speed	one	
	Tyres front /rear	10x16.5-10/8PR	
	Max.Travel speed	17Kmph	

Machine Rating

Rated Operating Capacity	800 Kgs
Pump Capacity	84 LPM
Tipping Load	1600kg
System relief at quick couplers	200 bar
Travelling Speed	0 ~17km/hr

Engine

Model	REHLKO
Fuel	Diesel
Max.Power @2600 rpm	42kw(56HP)
Max. Torque@1500rpm	225Nm
No.of. cylinder	3
Turbo	Naturally aspirated

Weight

Operating weight	2690kg
------------------	--------

Electrical

Battery	130AH
Alternator	100Amp

Capacity

Fuel	62L
Engine oil	8L
Coolant	12L
Hydraulic system	62L
Transmission	16L

Drive system

Transmission	Hydrostatic drive with hydraulic pilot Operated variable displacement Tandem pump with heavy duty radial Piston bidirectional motor
Type of Drive	4WD-gear Drive

Control

Vehicle steering	Skid steering ,Controlled by a left hand side single Joystick
Loader Hydraulic tilt and lift	Single joystick on right hand side
Front Auxiliary (std)	Electrical switch on right hand Side joystick

Features

Auxiliary hydraulic	Electrically activated front auxiliary hyd.
Heavy duty gear boxes with slip-free Gear	Axles of high ductile forgings, self – lubricating
Electronic Instrumentation	Operating Led lights, front and rear
Parking brake	Seat belt
Seat bar	Rear window for emergency exit
ICAT Certification	ROPS/FOPS cabin

Attachments

Sweeper collector	Shredder
Ripper tooth	Snow blade
Backhoe	stump grinder
Pallet forks	Bucket
Industrial grappler	Angle brooms
Rock breaker	Water kits
Snow blower	Stabilizers
Steel tracks (Track over tyres)	Scrapers

Optional

Self leveling valve
Anti stalling feature
Air conditioning
aux. hydraulics high flow

**DELKEEN SOLUTIONS LLP
AUTHORIZED DEALER FOR BIHAR AND JHARKHAND**

India.
Phone:- +91-120-4746300

Phone:- +917903510813 |
www.DELKEEN.com

Note: All are variable within +1.5% Vert Equipment Pvt Ltd.
Reserve the right to change specification without prior notice.